



ASYNCHRONOUS TRANSFER MODE (ATM) VERSUS INTERNET PROTOCOL (IP) FOR VOICE, DATA AND VIDEO TRANSMISSIONS

Olabomi O.E.¹, Petinrin J. O.² and Olawale K. O.¹

¹Department of Science Technology
Federal Polytechnic, Offa, Kwara State.
ebenezerolaosebikan@yahoo.com

²Department of Electrical and Electronic Engineering
Federal Polytechnic, Ede, Osun State

ABSTRACT - This paper investigates the comparison of Voice, Data and Video over Asynchronous Transfer Mode (VoATM) and Internet Protocol (VoIP) in terms of received traffic, end-to-end delay, packet jitter, packet drop ratio, and so on. An IP and ATM based networks consisting of ten sources and destinations with suitable network equipment and links was created separately, and the network performances for both network scenarios were compared. OPNET Modeller 14.5 (Education version) was found useful to simulate the configured quality of service (QoS) blocks for both IP and ATM networks. The simulation results show that ATM has the ability to cope with congestion because of its lower end-to-end delay and jitter due to its virtual path connections, whereas delay is high in IP which results into its poor congestion management. Meanwhile, IP performs better for less voice and data density.

Keywords: Protocol, Packet, Network, Traffic, Switching, Congestion, Quality of Service.

1 INTRODUCTION

Internet telephony allows the transmission of voice on the internet, unlike before when voice can only be transmitted on the Public Switch Telephone Network (PSTN) in which switches, copper wires and lines are used for the communication. Today, internet telephony allows data, voice and video to be transported on a single network setup [Green and Fleming, 2002].

Many technologies have been designed for the transmissions of data, voice and video over the internet such as; IP, ATM, Ethernet, synchronous optical network (SONET) and so on [Manish, 2000]. The familiar applications of these technologies are; hypertext transfer protocol (HTTP), file transfer protocol (FTP), Telnet and so on. Internet telephony can take the form of the following [Ayanoglu and Akar, 2011]:

- i. Communication between PSTN and PSTN. For example, BT broadband voice.
- ii. Communication between computer and PSTN. For example, call serve.
- iii. Communication between a computer to another computer. For example, Skype.

ATM and IP are two emerging technologies provided to transport network traffic with some special requirements to give the expected quality of service. Quality of service is said to be provisions of priority to users, data flows or applications [Cisco, 2008]. Priority can be end-to-end delay, dropping probability, jitter, bit rate and so on which are guaranteed in a network for the quality of service.

Voice over IP (VoIP) is a packet switching network which transmit packet from end to end. It dynamically shares bandwidth to numerous links based on their transmission activities. The IP is a connectionless protocol that allows packets to take many paths to reach the end point. The paths are used

by all the packets and this enables efficient location of resources with less congestion [Ayanoglu and Akar, 2011]. Header information attached to the packets delivers them to the right destination. Fig. 1 shows the packet format of VoIP.

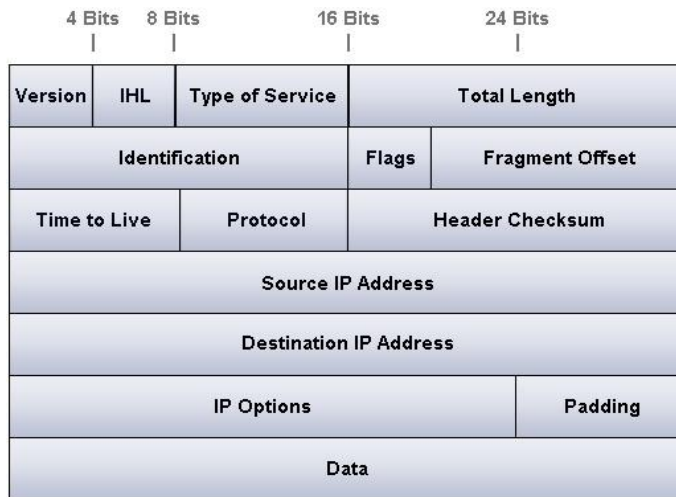

Fig. 1 Packet format of VoIP

Quality of service provides better network service by improving the following features in IP network;

- i. Loss characteristics improvement.
- ii. Network traffic shaping.
- iii. Dedicated bandwidth supported.
- iv. Managing and avoiding network congestion.
- v. Setting traffic priorities across the network.

Voice over ATM is a cell switching technology which is similar to packet switching except that the switching does not necessarily occur on packet boundary. It offers similar operations to packet switching and circuit switching networks. It uses asynchronous time division multiplexing and encodes data into small fixed sized packets called cells [Regis, 2002]. Fig. 2 shows the ATM cell structure.

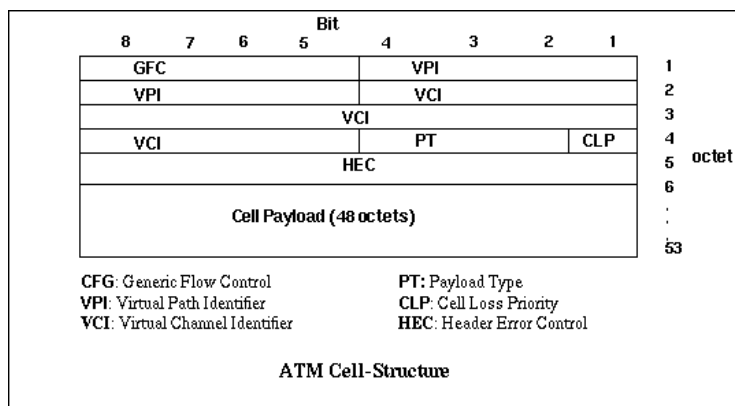

Fig. 2 ATM cell structure.

Quality of service provides better network service by improving the following features in ATM network;

- i. cell transfer delay
- ii. cell delay variation
- iii. cell loss ratio

2 COMPARISON BETWEEN VoIP AND VoATM BASED ON LITERATURE SURVEY

Table 1 describes the comparison between VoIP and VoATM based on literature survey;

Table 1: Comparison between VoIP and VoATM.

	VoIP	VoATM
1.	It is a packet switching network which transmit packet from end to end. It dynamically allots bandwidth to numerous link based on their transmission activities [Ayanoglu and Akar, 2011]	It is cell switching technology which is similar to packet switching except that the switching does not necessarily occur on packet boundary [Green and Fleming, 2002].
2.	A connectionless network protocol in which packets are transport through different path from source to destination. All packets are shared by packets from different transmissions [Manish, 2000]	A connection-oriented protocol which allows user to specify to the resources required on a per-connection basis dynamically [Cisco, 2008].
3.	It allows voice to be transport over a single packets network line both fax and modem data. [Manish, 2000].	It uses of multiservice, high speed, scalable technology but it is not generally in use as a result of expensive services. [Green and Fleming, 2002]
4.	It earlier utilizes IP QoS protocol mainly RSVP as prioritization techniques for VoIP but now Type of Service (ToS) of IP header is used to categorize traffic at the edge between the client and the provider or internet service provider (ISP) [Hersent <i>et al</i> , 2005].	The prioritization techniques employed by ATM is Quality of Service (QoS) parameters. The QoS parameters are Cell Transfer Delay (CTD)- This considered the maximum and minimum CTD, peak-to-peak Cell Delay Variation (CDV)- peak-to-peak CDV and instantaneous CTD is employed, and Cell lost Relation (CLR)- The percentage of cells that are lost in the received due to error or congestion [Cisco, 2004].
5.	Compression of voice data is necessary because of traffics that are transmitted over a low speed links [Regis, 2002].	Voice compression is not important due to ATM sufficient bandwidth. However compression can be necessary in ATM-Frame hybrid in which ATM is configured to support compression because of frame relay that required compression. [Neelakanta, 2000]
6.	The variation in latency causes non-smooth voice stream. Thus there is no guarantee of packet delivery due to unpredictable delay. This is controlled by a jitter buffer that avoids delay [Hersent, et al, 2005].	Variation of delay is reduced as a result of dynamic bandwidth Circuit, which does not send constant bit stream of cells but transmit only at an active voice call. [Neelakanta, 2000]
7.	It utilized method of silence suppression to save bandwidth [Cisco, 2008].	Silence suppression is not necessary in ATM network but it is used in hybrid network [Neelakanta, 2000].
8.	There are lot of overhead in IP network due large IP header size which is 20bytes [Neelakanta, 2000]	ATM cell 5-byte headers which are fewer compared to IP packets headers size. [Neelakanta, 2000]
9.	VoIP make use of echo cancellers between the ends of the voice transmitter and receiver [Regis, 2002].	VoATM transport data, voice, and video at very high speed. Meanwhile it uses the same echo cancellation method [Regis, 2002].
10	The International Telecommunication Union (ITU-T) operability standard for voice application over IP is H.323 which describes terminal and other entities that provide multimedia communications services over packet-based Networks which may not provide a guaranteed QoS. Then the future standard is H.225.0 [Hersent, et al, 2005].	The ITU-T recommended specification for ATM IS 1.363.2, which emerge as the standard choice as the ATM Adaptation Layer 1 (AAL1) protocol in ATM Contact Bit Rate (CBR) service proved inefficient for voice transmission. The emerged standard is called AAAL2 Variable Bit Rate (VBR) [Neelakanta, 2000].

3 EXPERIMENTAL DESIGN OF NETWORK SCENARIOS FOR VoIP AND VoATM

Material/Item: OPNET Modeller 14.5 (network simulation software).

Method:

- i. Voice application and web browsing applications were configured appropriately using OPNET Modeller.
- ii. Quality of service for IP and ATM were also configured.
- iii. An IP based networks consisting of ten sources and destinations with suitable network equipment and links was created.
- iv. An equivalent ATM based networks consisting of ten sources and destinations with suitable network equipment and links was also created.
- v. The network performance for both IP and ATM was compared in terms of received traffic, end-to-end delay, packet jitter, packet drop ratio, and so on.

The topologies of the experimental networks for both IP and ATM are shown in Fig. 3 and Fig. 4 as follows:

Experimental ATM and IP Network Topology

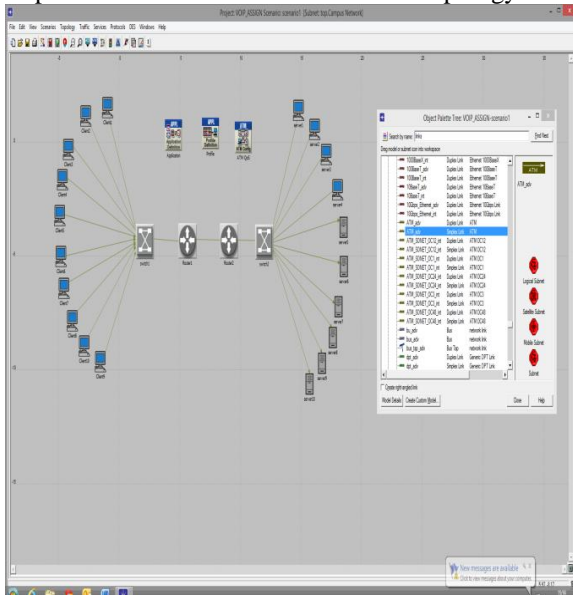

Fig. 3 ATM topology

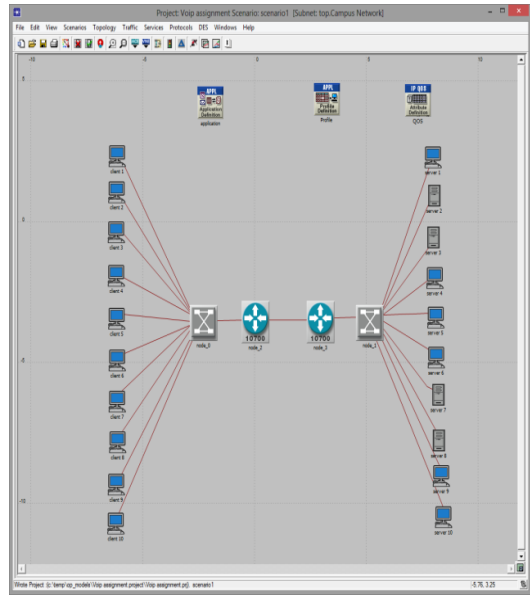

Fig. 4 IP topology

The following descriptions are distributed per each among the ten sources;

- Video conferencing
- Voice
- Email
- File Transfer Protocol (Ftp)
- Hypertext Transfer Protocol

Clients 1 and 2 – Video conferencing

Clients 3 and 4 – Voice

Clients 5 and 6 – Email

Clients 7 and 8 – Ftp
Client 9 and 10 –Http

4 RESULTS AND DISCUSSIONS

Simulation Results

Table 2 Components used to build both IP and ATM networks.

COMPONENT PART	IP	ATM
Work station	ethernet_wkstn_adv	atm_wkstn_adv
Router	Ethernet_tr_slip8_gtwy_adv.	Atm4_ethernet2_slip8_gtwy_adv
Switch	Ethernet16_layer4_switch-adv	Atm16_crossconn_adv
Server	ethernet_server_adv	atm_server_adv
Link	1000baseT	Atm_adv

I. Traffic Received in Packets/Sec; and in Bytes/Sec

Fig. 5 shows that the video conference traffic received in terms of Packet/sec is 10 packets/sec after 2 minutes for both ATM and IP. This is an indication that ATM and IP have similar performance for traffic received in packets/sec.

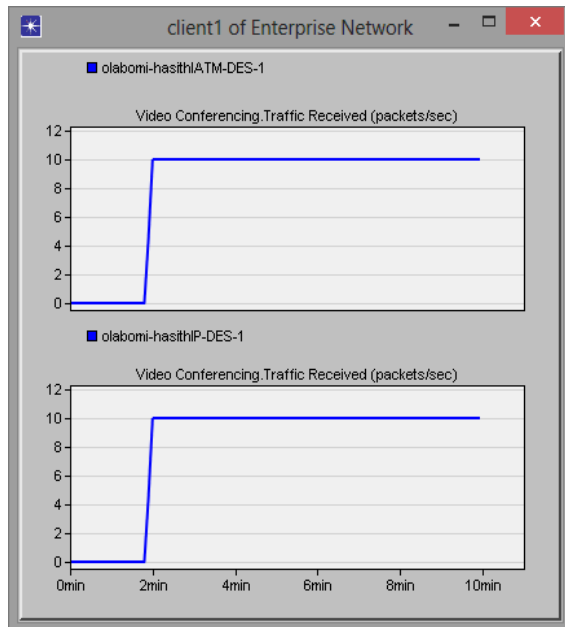

Fig. 5 Video Conference Traffic received in Packet/sec.

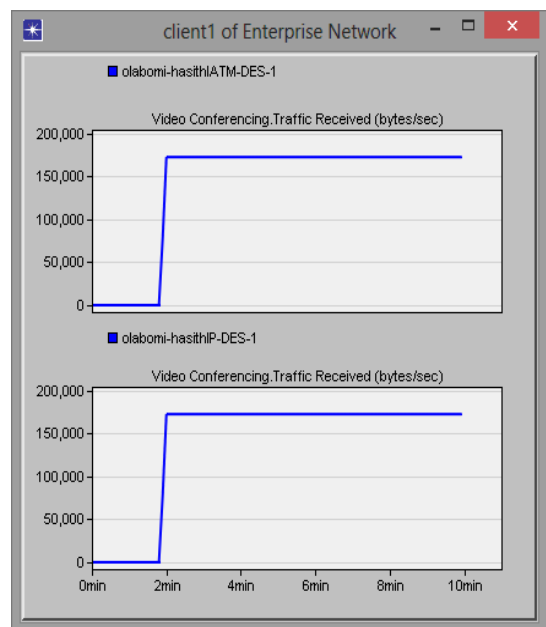

Fig. 6 Video conference Traffic received in bytes/sec

Fig. 6 shows that the video conference traffic received in terms of bytes/sec is above 150,000 bytes/sec (150Kbytes/sec) after 2 minutes for both ATM and IP. This is an indication that ATM and IP also have similar performance for traffic received in bytes/sec.

II. Traffic Received in Bitts/Sec; and End-To-End Packet Delay

Fig. 7 shows the maximum ftp traffic received in ATM to be above 60 bits/sec, while the maximum ftp traffic received in IP is above 1000 bits/sec (1Kbits/sec). This indicates that IP performs better in terms of ftp traffic.

Fig. 8 shows the video conference packet end-to-end delay in ATM to be constant on 0.003sec (3ms), while that of IP is constant on 0.0045sec (4.5ms). This indicates that ATM requires less response time to send data from one client to another client because delay is less. So ATM has good response at all types of traffics but IP gives poor results because of its random path selections.

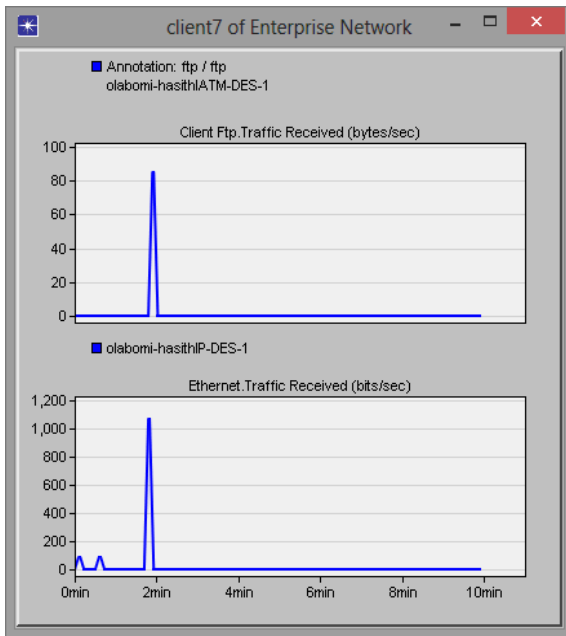

Fig. 7 Ftp Traffic received in bits/sec

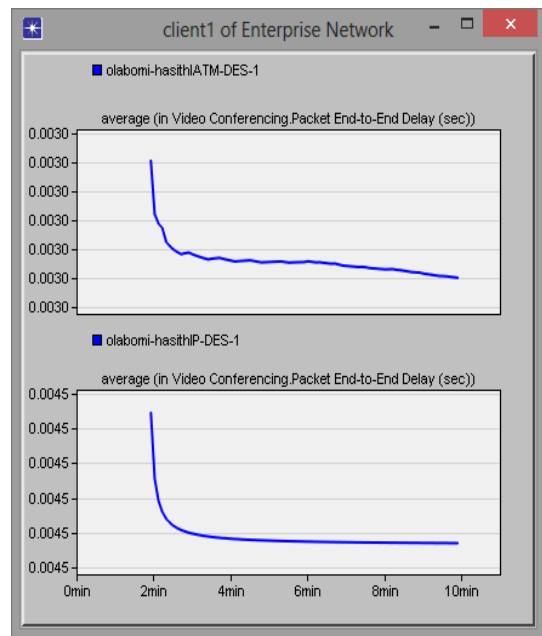

Fig. 8 End-to-end packet delay

III. Point-To- Point Throughput; and Point -To- Point Utilization

Fig. 9 shows the mail and http packet end-to-end throughput in ATM to be little above 200,000bits/sec (0.2Mbits/sec), while that of IP is 1,500,000bits/sec (1.5Mbits/sec). This indicates that point-to-point throughput is better in IP than ATM. Although end-to-end throughput is far better in ATM during congestion. Fig. 10 shows the ftp and mail packet point-to-point utilization in ATM to be 0.14bit/sec, while that of IP is 0.15bit/sec. This indicates that point-to-point utilization is lesser in ATM. This indicates that IP required more amount of bandwidth because large amount of packets are utilized by it. Utilization is less in ATM but this is an advantage at the time of congestion.

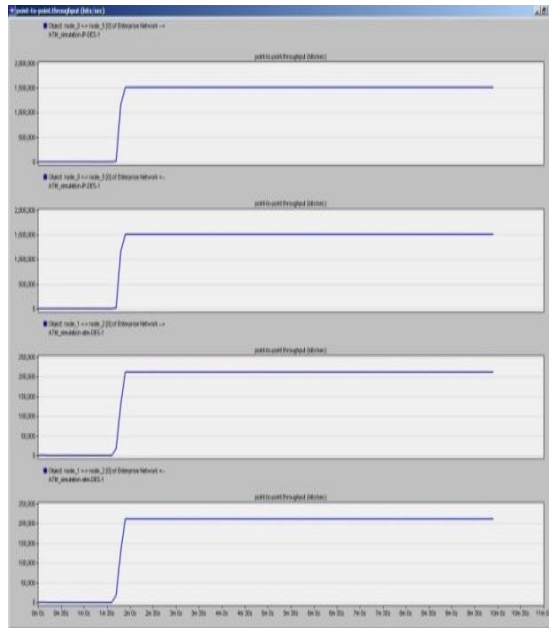

Fig. 9 Point-To-Point throughput (bits/sec)

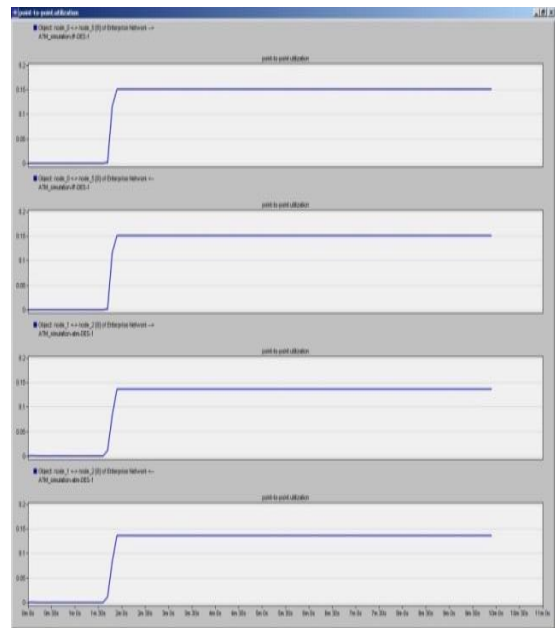

Fig. 10 Point-To-Point Utilization

General Summary

- vi. Figs. 5, 6 and 7 describe the volume of traffic received at the server end in both byte per second and packet per second. The traffic received (byte/second and packet/second) in both ATM and IP networks are relatively similar in video conferencing, but there is more traffic received in FTP traffic in IP than ATM.
- vii. Fig. 8 describes how long it takes the packets to travel from one end to another end in the network setup. There is less delay in ATM than IP. High delay of IP network does not support voice traffic. This delay causes packet drops and data lost.
- viii. Fig. 9 describes how successfully the traffic is delivered across the network configuration. Point-to-point throughput in byte per second is better in IP network with less data density, but far better in ATM during congestion.
- ix. Fig. 10 shows how efficiently the bandwidth of the network setup can be utilised for voice and data transmission. Point-to-point utilisation is slightly better in IP than ATM. The value is less in ATM network because it uses multiservice, high speed and scalable technology.

5 CONCLUSIONS

A comparison of ATM and IP technologies for voice and data transmissions in internet telephony is being given. ATM is found to have a good QoS support. It is a better option in terms of voice traffic. IP network is a connectionless protocol which is a disadvantage especially in transmitting large volume of voice and data traffics.

The simulation results show that link utilization and delay are the major factors in voice and data network. Link utilization is small in ATM which helps the voice traffic to be transported faster compared to IP network. ATM has the ability to cope with congestion because of its lower end-to-end delay and jitter due to its virtual path connections, whereas delay is high in IP which results into its poor congestion management. Meanwhile, IP performs better for less voice and data density.

Furthermore, voice and data over ATM though found effective with respect to quality of service and speed, but very expensive because it uses multi-service and scalable technology, voice over IP is a

solution of low cost because it allows voice to be transported over a single packet network. ATM can cope with congestion than IP. Meanwhile, IP network performs better for less voice and data density.

REFERENCES

1. Ayanoglu E and Akar, N, (2011). Broadband Integrated Services Digital Network. Center for Pervasive Communications and Computing, UC Irvine. ISBN 0-8493-1805-X.
2. Hersent O, Petit J.P, et al, (2005). IP Telephony: Deploying voice-over-IP protocol. John and Sons. ISBN: 0470023597.
3. Green, J.H and Fleming, J, (2002). Voice and Video over IP. McGraw-Hill. ISBN: 0071382488.
4. Manish Sehgal, (2000). Selection of appropriate data network for transferring voice traffic. MSc. Dissertation, Wichita State University.
5. Cisco, (2000). Guide to ATM Technology. Cisco Publications. Cisco system, Inc., 6 San Jose, CA, USA.
6. Regis J. Bates, (2002). Broadband Telecommunication. Second Edition. McGraw-Hill.: 0071409580.
7. Cisco, (2004). "Reason for VoIP". [Online]. Available from: www.cisco.com/resources_center/articles. [Accessed on 18th October, 2015].
8. Cisco, (2008). "Voice and data integration technologies". [online] Available at: www.cisco.com/Data_integration_Technologies. [Accessed on 18th October, 2015].
9. Neelakanta, P. S. (2000). A Textbook on ATM Telecommunications: Principles and implementation. Boca Raton [fla.] CRC press. ISBN: 084931805X.
10. Gilbert Helt, (1999). Voice and Data Internetworking. McGraw-Hill Publications.